



inline design
DN 25

PLASTIC BACK PRESSURE REGULATOR LPS® I

Application

This pressure relief valve has been specially designed to limit the pressure of aggressive gases in chemical plant-engineering tanks. Together with our LPR pressure reducing valves, pressure blanketing/ventilation can be realised easily and reliably.

Design

The large proportioned, spring-loaded diaphragm actuator with directly-controlled valve seat ensures precise control with low hysteresis. The regulators function without auxiliary power supply. High overpressure strength and safe regulator function is achieved by means of the supported diaphragm with long spindle guide. The regulator has a low degree of clearance volume.

Description

The components coming in contact with the product are manufactured from plastic PP/PP_{el.}, PVDF, ECTFE or Tantalum. The diaphragm and seals are made of PTFE and the regulator seat is made of perfluoroelastomer (FFKM: Isolast®, Chemraz®, Kalrez®) as standard.

These materials guarantee high corrosion resistance and excellent sealing, even at zero flow.

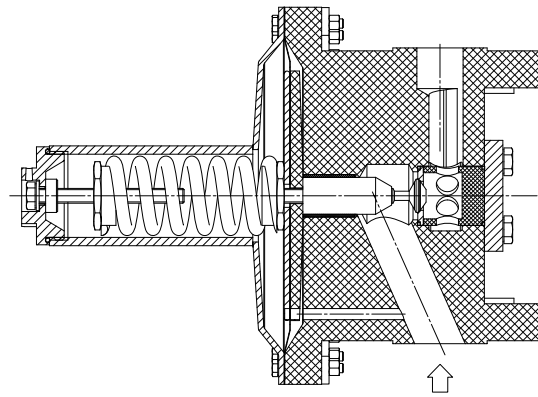
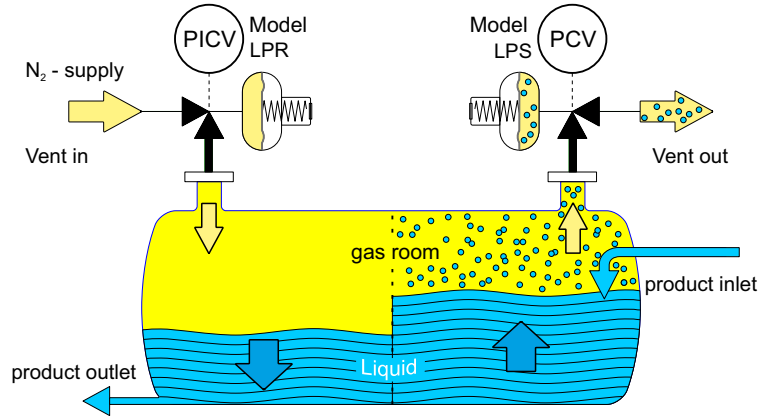

Technical data

Nominal diameter:	DN 25 / 1"		
Regulating range P1:	L..	to 500 mbar	
Inlet pressure P1:	max. 6 bar		
Vakuum proof			
Pressure connections:	Flange		
Weight:	PP 4,8 kg PVDF 7,1 kg ECTFE 8,7 kg		
*Temperature:	PP, PP _{el.}	-20 ° to + 80 °C	
	PVDF	-20 ° to +140 °C	
	ECTFE	-20 ° to +160 °C	
Testing and inspection:	According to IEC 60534-4		
Pressure tightness:	Bubble tight sealing category VI		

*Dependent on pressure conditions

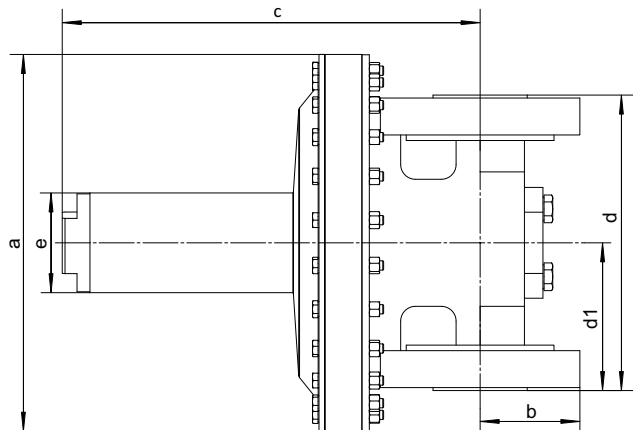

Model dimensions	pressure connection	a	b	c	d	d1	e
LPSI-025-...-...-... in plastic design	DN25 PN10 ANSI 1" 150 lbs	Ø 204	58	235	160	80	Ø54





inline design
DN 25

MODEL CODE LPS[®]I PLASTIC

1		2			3		4			5		6		7
Design		Nominal diameter DN/ pressure connection			Flow capacity		Regulating pressure range			Material		Options		Specials
LP	S I -	025	.	-	..	-	...	-	...	-	.	-	Xn	

2 Nominal diameter DN/ Pressure connection

D	Flange:	DIN EN 1092-1, DN 25 PN 16
A	Flange:	ANSI B 16.5, 1" 150 lbs

3 Flow capacity

20	Seat	ø20 mm	kv = 6.1
----	------	--------	----------

Flow table for seat 20 [flow quantities in Nm³/h]

P1 [mbar rel.]	2	5	10	16	25	40	50	80	100	160	250	400
Atm.	7	11	16	21	26	33	36	46	52	63	81	103
-2	10	14	18	22	27	33	37	47	52	64	82	103
-5	14	16	20	24	28	35	38	48	53	64	82	104
-10	18	20	23	26	31	37	40	49	54	65	83	105

It is recommended to design for operation at a maximum of 70% of the flow values.
P1 = regulating pressure

4 Regulating pressure range P1 (mbar)

L01	2 to 10	L10	16 to 100
L02	4 to 20	L20	30 to 200
L05	8 to 50	L50	on request

5 Material

	Housing/ internal components/ upper section	Seat seal	Diaphragm/ Regulating range
P	PP/PP/SS	K FFKM	P PTFE/ L..
Y	PP/PVDF/SS	C FFKM kon- forms to FDA	F *PTFE/ L..
D	PVDF/PVDF/SS		
V	PVDF/PVDF/SS		
E	PPeI./PVDF/SS		
T	ECTFE/Tantalum/SS		

The housing/internal components/spring housing, seat and diaphragms can be combined in any order.

*PTFE with FKM - Back-up - Diaphragm

6 Options

E	BSP 1/4" external impulse connection
---	--------------------------------------

7 Specials

X0 If you require, for example, PED, special connections, rain hood ..., please enter an X in this field with the number of desired Specials. Each of the specials must be described in writing. The analysis of materials 3.1 B and ATEX - certificates cannot be issued for plastic models.
Xn For special versions and certifications, please contact the manufacturer or the appropriate sales representative.

Pressure / flow characteristic

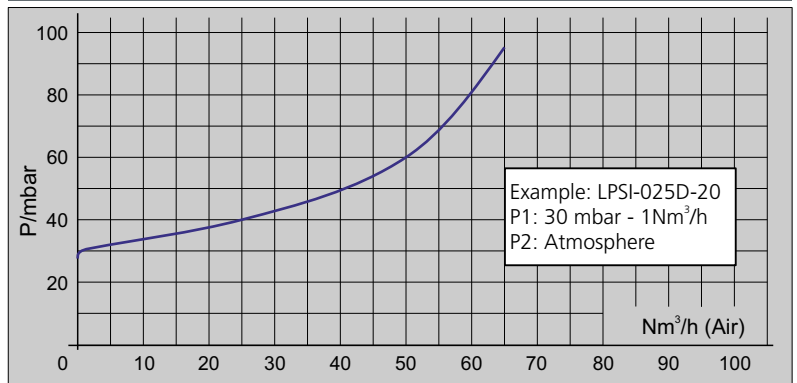

Installation

The preferred installation position is with vertical diaphragm housing and horizontal input. Pressure fixed unit is adjusted in this position. The output pressure increases by approximately 4 mbar for installation with horizontal diaphragm housing. The installation position must be specified.

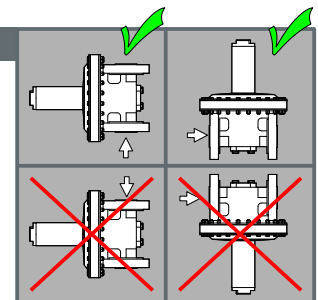

Mounting and start up

- Before connecting the pressure regulator please make sure
- LPSI adjust overflow pressure: (Relative pressure)
- 1.1 to compare the plant data with the name plate
- 2.1 set a light flow (1 Nm³ /h). Set the pressure +/- as required using a hexagonal wrench
- 1.2 the values marked on the name plate are the values measured during our functional inspection
- 2.2 the setting can be secured with a seal.
- 1.3 to check the corrosion resistance of the material
- 1.4 to blow out impurities in the pipes
- 1.5 to note the flow direction – it is marked with an arrow on the housing
- 1.6 to open inlet pipes slowly.